

721 Series Spectrophotometer

Instruction Manual

Contents

Safety

General

Electrical

Warning

Working Principle

Unpacking Instructions

Specifications

Installation

Introduction

Description of keys and operating method

Operating Procedures

Maintenance

Calibration and trouble shooting

Replace W lamp

Calibration of Wavelength Accuracy

Trouble Shooting

Safety:

The safety statements in this manual comply with the requirements of the HEALTH AND SAFETY AT WORK ACT, 1974.

Read the following before installing and using the instrument and its accessories. The 721 series should be operated by appropriate laboratory technicians.

General:

The apparatus described in this manual is designed to be used by properly trained personnel in a suitable equipped laboratory. For the correct and safe use of this apparatus it is essential that laboratory personnel follow generally accepted safe procedures in addition to the safety precautions called for in this manual.

The covers on this instrument may be removed for servicing. However, the inside of the power supply unit is a hazardous area and its cover should not be removed under any circumstances. There are no serviceable components inside this power supply unit. Please avoid touching the high voltage power supply at all times.

Some of the chemicals used in spectrophotometer are corrosive and/or inflammable and samples may be radioactive, toxic, or potentially infective. Care should be taken to follow the normal laboratory procedures for handling chemicals and samples.

Electrical:

Before switching on the apparatus, make sure it is set to the voltage of the local power supply.

(The Voltage Switch is on the bottom of the instrument. 220V & 110V are under your choice. Let the visible value on the switch match your local power supply.

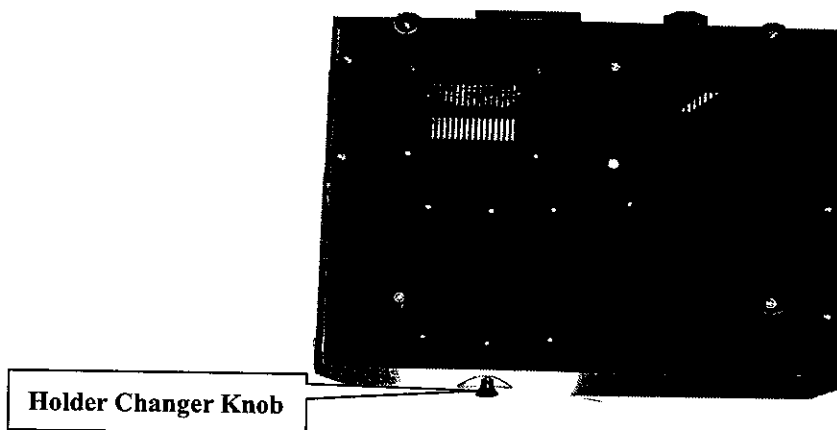

Fig. 1-1

The power cord shall be inserted in a socket provided with a protective earth contact. The protective action must not be negated by the use of an extension cord without a protective conductor.

Warning:

Any interruption of the protective conductor inside or outside the apparatus or disconnection of the protective earth terminal is likely to make the apparatus dangerous. Intentional interruption is prohibited.

Whenever it is likely that the protection has been impaired, the apparatus shall be made inoperative and be secured against any unintended operation.

NEVER touch or handle the power supply due to the high voltage.

The protection is likely to be impaired if, for example, the apparatus

- Shows visible damage.
- Fails to perform the intended measurements.
- Has been subjected to prolonged storage under unfavorable conditions.
- Has been subjected to severe transport stresses.

Working Principle:

The spectrophotometer consists of five parts: 1) Halogen or deuterium lamps to supply the light; 2) A Mono-chromator to isolate the wavelength of interest and eliminate the unwanted second order radiation; 3) A sample compartment to accommodate the sample solution; 4) A detector to receive the transmitted light and convert it to an electrical signal; and 5) A digital display to indicate absorbance or transmittance. The block diagram (Fig 1-2) below illustrates the relationship between these parts.

Block diagram for the Spectrophotometer

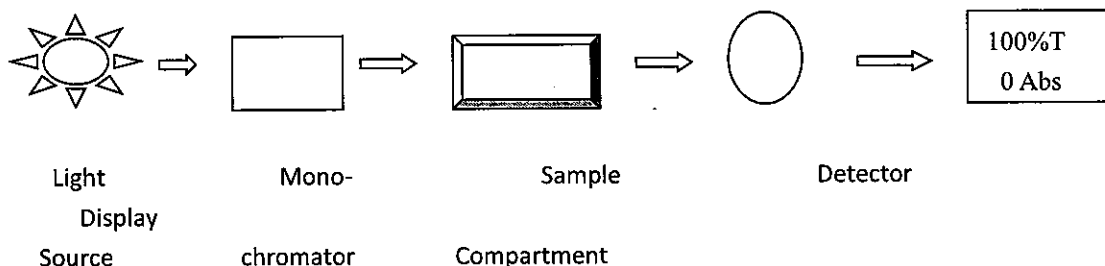

Fig1-2

In your spectrophotometer, light from the lamp is focused on the entrance slit of the mono-chromator where the collimating mirror directs the beam onto the grating. The grating disperses the light beam to produce the spectrum, a portion of which is focused on the exit slit of the mono-chromator by a collimating mirror. From here the beam is passed to a sample compartment through one of the filters, which helps to eliminate unwanted second order radiation from the diffraction grating. Upon leaving the sample compartment, the beam is passed to the silicon photodiode detector and causes the detector to produce an electrical signal that is displayed on the digital display.

Unpacking Instructions:

Carefully unpack the contents and check the materials against the following packing list to ensure that you have received everything in good condition.

Packing List

Description	Quantity
• Spectrophotometer.....	1
• Cable.....	1
• Glass Cuvette.....	1 Set of 4
• English Manual.....	1
• Warranty Card.....	1
• Quartz Cuvette (available for UV model)	1 Set of 2
• Software (optional)	1

NOTE: If there is any change in this package, an accessories & spare parts list attached should be referred to as final.

Specifications:

Model	721	722	752
Wavelength Range	350-1020nm	320-1020nm	190-1020nm
Spectral Bandwidth	6nm	5nm	
Optical System	C-T Single Beam, Grating 1200lines/mm		
Wavelength Accuracy	±3nm	±2nm	
Wavelength Repeatability	≤1nm		
Photometric Accuracy	±1%T	±0.5%T	
Photometric Repeatability	0.5%T	0.2%T	
Photometric Range	0-200%T, -0.3A~3A		
Stray Light	≤0.3%T @ 220nm,340nm		
Stability	±0.004A/h @500nm		
Display	4 LCD		
Photometric Mode	T, A, C		
Detector	Silicon Photodiode		
Light Source	D2 lamp(1500hr),Tungsten lamp(2000hr)		
Output	RS232 Port		
Power Requirement	Bi-volt (220V & 110V)		
Dimensions (W x D x H)	450 x 520 x 320mm		
Weight	8kg	10kg	

Installation:

1. After carefully unpacking the contents, check the materials with the packing list (page 3) to ensure that you have received everything in good condition.
2. Place the instrument in a suitable location away from direct sunlight. In order to have the best performance from your instrument, keep it as far as possible from any strong magnetic or electrical fields or any electrical device that may generate high-frequency fields. Set the unit up in an area that is free of dust, corrosive gases and strong vibrations.

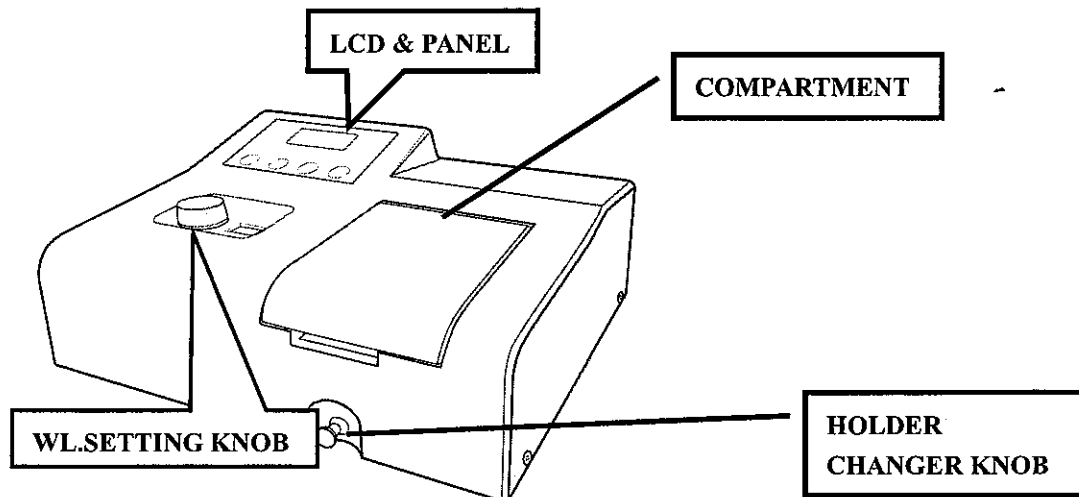

Fig.1-3

3. Remove any obstructions or materials that could hinder the flow of air under and around the instrument.
4. Use the appropriate power cord and plug into a grounded outlet.

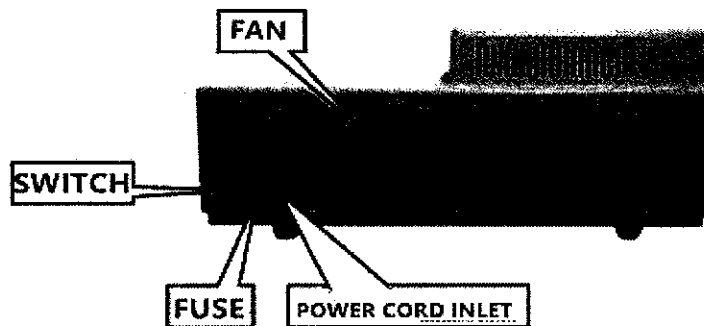

Fig.1-4

5. Turn on your spectrophotometer. Allow it to warm up for at least 20 minutes before taking any readings.

Introduction:

Visible spectrophotometer, an analytical instrument commonly used in physic-chemical laboratories to make quantitative and qualitative analysis of specimen materials in the ultraviolet, visible spectral range finds much scope for its service in such fields as medicine, clinical examination, biochemistry, quality control, petro-chemical industry and environmental protection.

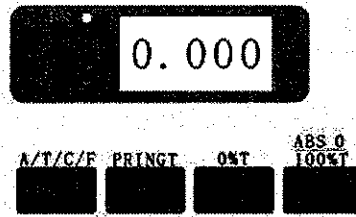

Fig. 1-5

Description of keys & Operating Methods

The four keys on the keyboard are:

1. **MODE**
2. **PRINT**
3. **▽ /0%T**
4. **△ 0Abs/100%T**

MODE key used to select the Transmittance, Absorbance, Concentration and Factor mode.

PRINT key has two functions:

- a. To be used in RS232 serial interface and data transmission (one –way transmission from the instrument to the computer).
- b. When in print mode.

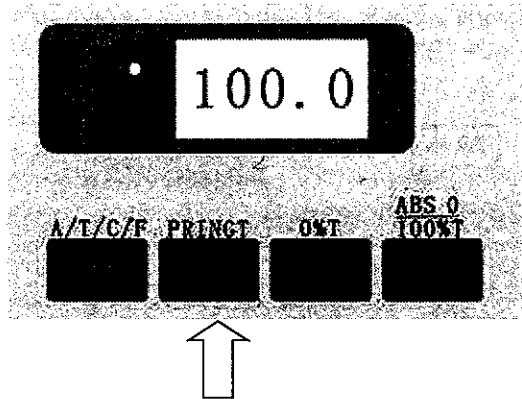

Fig.1-6

▽ /0%T key has two functions :

- a. To set zero. It is effective only in **T** mode. Insert black block into the second slot of the cuvette, then close the sample compartment cover. Pull the cuvette holder to the position of the second slot. Press the key, and it will show 000.0. (Fig.1-7)

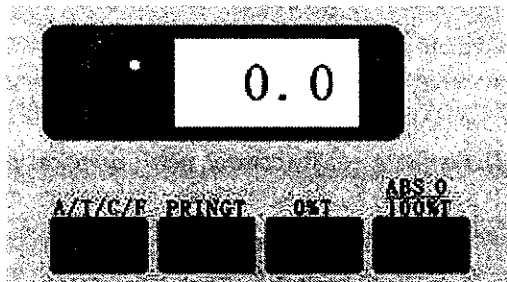



Fig.1-7

- b. As the descending key, when in F mode, press the $\nabla/0\%T$ key and the F value will decrease by 1. Holding the key will speed up the decrease. When the F value reaches 0, another press on the key will change the value to 1999.

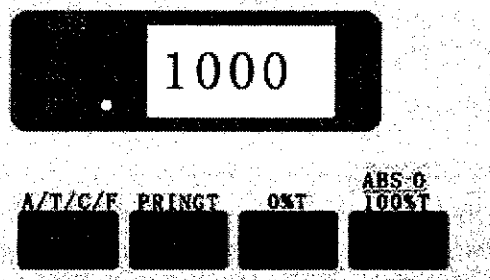

Fig.1-8

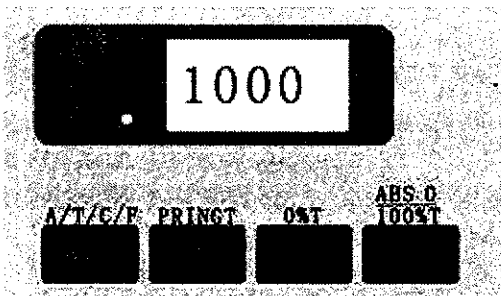

Fig.1-9

$\Delta/0Abs/100\%T$ key has the following two functions:

- a. When in A or T mode, close the sample compartment, press the key and it will read 0.000 (Fig.1-10) or 100.0 (Fig.1-11).

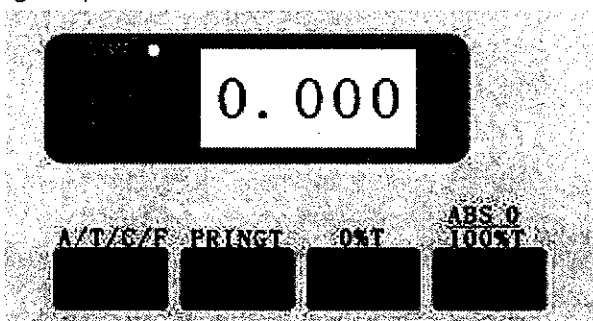

Fig.1-10

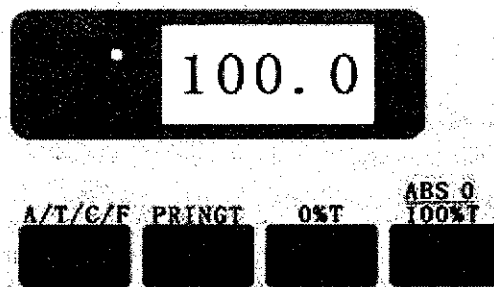

Fig.1-11

- b. To be used as the ascending key (effective only in F mode). Press the key and the F value will increase by 1 (Fig.1-12 & Fig.1-13). A long press will speed up the increase. When the F value reaches 1999, another press of the key will change it to 0. And still another press it will increase by 1.

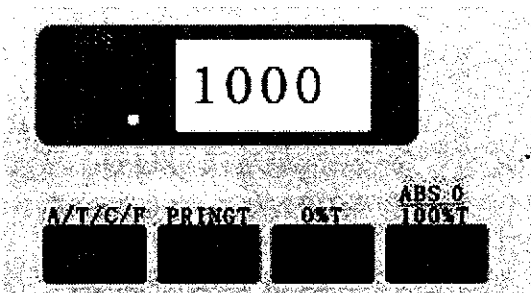

Fig.1-12

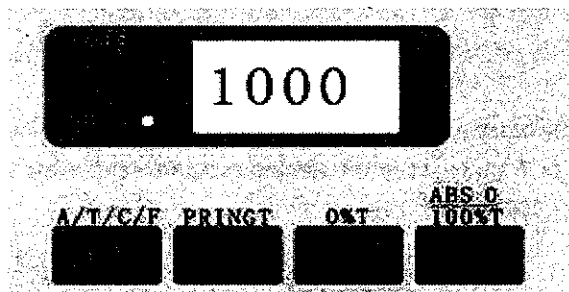

Fig.1-13

Example :

Let the F value be 1500.

Method I

- a. Press **MODE** to set it at F mode. (Fig.1-14)

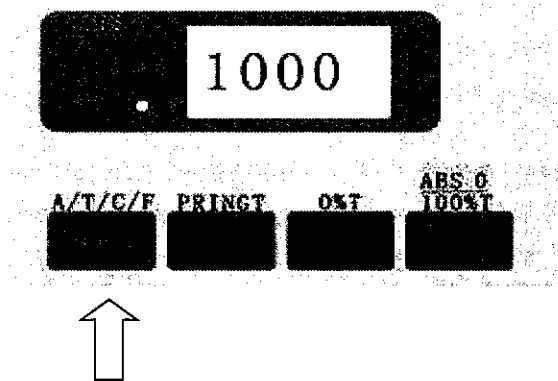

Fig.1-14

- b. If the current F value is 1000, press the $\Delta/0\text{Abs}/100\%T$ key, until it goes up to 1500. (Fig.1-15)

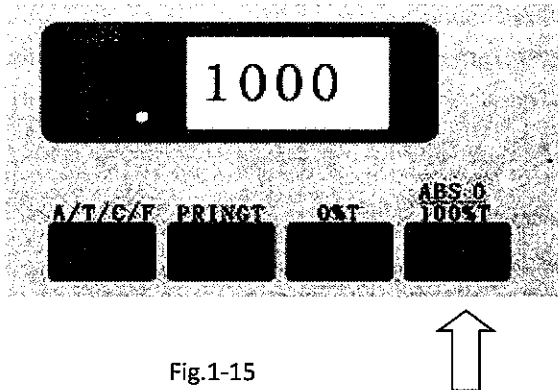

Fig.1-15

- c. Press the **MODE** key, and the current F value shows 1500 (Fig.1-16). Then C mode automatically appears. Suppose the A value measures 0.234, then the C value reads 0.351.

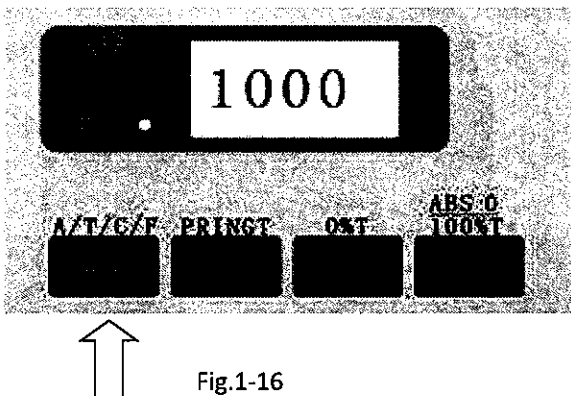

Fig.1-16

Method II

- Press **MODE** key to set it at F mode.
- If the current F value is 1000, press the $\Delta/0\text{Abs}/100\%T$ key, till it reaches 1500. Press the **MODE** key again to go to C mode. If the value measures 0.234, then the C value reads 0.351.

Operation Procedures

1. Plug the instrument into a grounded outlet.
2. Turn the instrument on. Allow the instrument to warm up for 30 minutes.
3. Set to desired wavelength with the **Wavelength Knob**, press the **MODE** key to select A/T/C/F.
4. If you want to know T value, press **MODE** key to change to "T" mode, fill one of matched cuvettes with a blank solution.
5. open the sample compartment cover, set 0.000%T by pressing the **▽/0%T** key until display reads "0.000".
6. if you use air as reference sample, please close the sample compartment cover directly, and press the **△/0Abs/100%T** key until display reads 100.0.
7. open the sample compartment cover and Insert the cuvette into the cuvette holder, then close the sample compartment cover. read results directly on the digital display.

Maintenance

1. To ensure the steady operation of the instrument, it is recommended to use an AC voltage stabilized power source.
2. After operation, turn off the power and cut off the power supply.
3. Put a dusk cover with some desiccants over the instrument when it is not in use to keep it clean and dry.
4. After months of operation or after it is moved, the instrument should be checked for its wavelength accuracy.

Calibration & Trouble-shooting

After a long time of use, the instrument needs calibrating or repairing, as its performance index may have changed, here are some tips.

1. Replacement of tungsten-halogen lamp:

- 1) Turn off and unplug the instrument.
- 2) Remove the four screws on the sides of the spectrophotometer.
- 3) Remove the three screws on the front of the bottom of the spectrophotometer(Fig2-1)

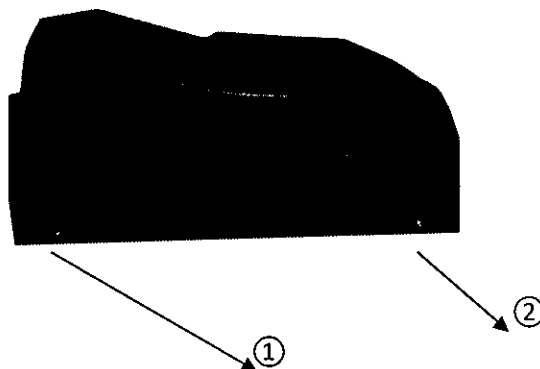

Fig. 2-1

- 4) Remove the **Cuvette Holder Control Knob** by unscrewing the rod counterclockwise.
- 5) Remove the WL. Setting Knob.
 - a) Use a Flat Head Screw Driver to pick the cover out from the knob.
 - b) Use a Spanner or Sleeve to loosen the screw in the knob, then remove the knob.

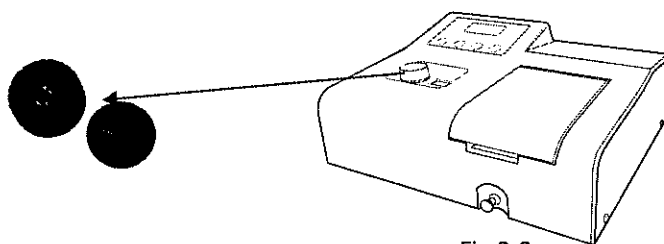

Fig.2-2

- 6) Remove the cover of the instrument very carefully and place it in the back of the instrument.
BE SURE NOT TO PULL PANEL WIRING LOOSE!
- 7) Unscrew the two screws **i** & **ii** from the **Lamp Cover** and remove the cover.(Fig.2-3)
(Caution: The cover may be HOT, be sure to wear gloves when act)

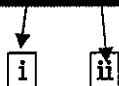

Fig.2-3

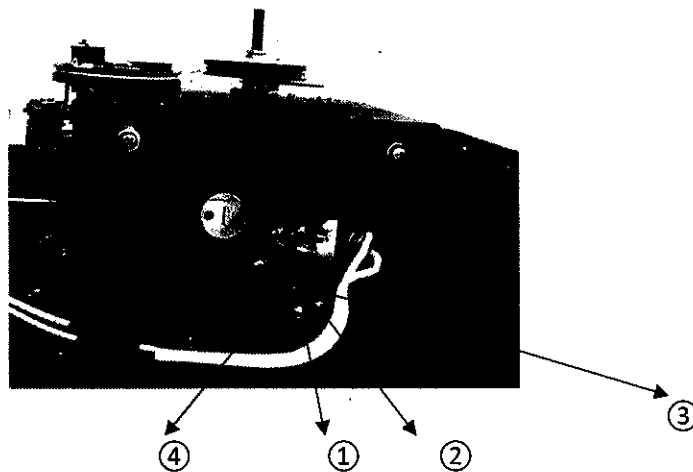

Fig. 2-4

- 8) Unscrew ① & ② in Fig.2-4, then unscrew ③ & ④. Unplug and remove the lamp from ceramic base (the white connector). Insert the new lamp; pushing it in as far as it will go. Then tighten screw ③ & ④.

CAUTION:

- a) Do not handle the lamp with bare fingers. Use tissue or cloth when handling lamp.
 - b) There's no difference in polarity of the two legs of Tungsten-halogen lamp.
- 9) Tighten screw ① & ②, Set the wavelength of the instrument at 500nm, Switch on the power, move the lamp up and down and from side to side, until its focus falls exactly on the

entrance slit. Observe the reading in T mode without adjusting the $\Delta/0\text{Abs}/100\%T$ key. Readjust the lamp to make the reading at its maximum.

- 10) Switch the instrument off, fixed the lamp cover and tighten the two screws. Reinstall the instrument cover. Be sure to prevent all wires from being pinched in the process.
- 11) Reinstall the seven screws. Reposition the Cuvette Holder Control Knob and the Wavelength Setting Knob.

2. Calibration of wavelength accuracy

1000 series spectrophotometer is checked for its wavelength accuracy by a point-to-point method against the two characteristic absorption peaks of a didymium filter---529nm and 808nm. In case the point-to-point measurement shows a wavelength different from the peak wavelength of the didymium filter (maximum permissible error is $\pm 2\text{nm}$), remove the wavelength knob, loosen the three positioning screws on the wavelength dial (Fig.2-5), adjust the dial pointer to the characteristic absorption peak wavelength value, and tighten the screws.

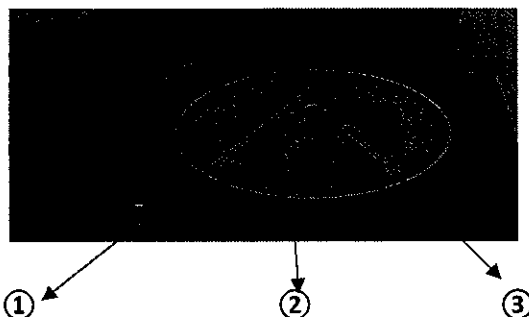

Fig.2-5

3. Troubleshooting

Troubles	Causes	Remedies
1.No functioning after power is on	1.Powersupply not connected. 2.Power fuse melted. 3.Loose contact of power switch.	1.Check power line. 2.Replace fuse. 3.Replace power switch.
2.Unstable display	1.Insufficient warm-up time. 2.Excessive vibration, strong air current near light source, or strong external light. 3.Unstable voltage 4.Poor grounding	1.Ensure 20 mins warm-up time. 2.Improve working conditions. 3.Use a voltage stabilizer. 4.Check ground connection.
3.Unable to set zero	1.black block in the light path. 2.Amplifier failure.	1.Remove the block. 2.Repair amplifier.
4.Unable to set 100%T	1.Tungsten-halogen lamp not lit. 2.Inaccurate light path. 3.Amplifier failure.	1.Check or repair lamp power circuit. 2.Readjust light path. 3.Call Repair amplifier.
5.Concentration incorrectly calculated	1.Display board out of order.	1.Repair or replace display board.